

PVC-TRAGROLLEN

Tragrollen mit PVC-Rohr und vorgeschmierten Querkugellagern, gegen Wasserspritzer geschützt, Lagerhalter aus Polyamidharz PA, Achse und Feder aus Stahl.

Auf Wunsch: Achse und Feder aus Inoxstahl, Rohr aus Spezial-PVC, Radialkugellager Typ 6002 bzw. 6202: aus Stahl, thermoplastischem Harz, Inoxstahl, thermoplastischen. Normale Betriebstemperatur TN: $-5 \div +50$ [°C].

RODILLOS LIBRES DE PVC

Rodillos libres con tubo de PVC montados sobre cojinetes oblicuos de bolas prelubricados y protegidos contra las salpicaduras de agua, con cabezas de resina poliamídica PA, eje y resorte de acero.

A petición: eje y resorte de acero inox, tubo de PVC especial, cojinetes radiales de bolas tipo 6002 o 6202: de acero, de resina termoplástica, de acero inox. Temperatura de trabajo normal TN: $-5 \div +50$ [°C].



Tabelle 7 **PVC-TRAGROLLEN SERIE 553.0 RODILLOS LIBRES DE PVC SERIE 553.0** Tabla 7

Typ tipo	D	s	da	d	M	T	E	a	b	T		ges.Rollengewicht kg peso total rodillo kg		Gewicht drehende Teile kg peso partes rodantes kg					
										min.	max.	L=200	mehr pro cm más, por cm	L=200	mehr pro cm más, por cm				
553.0.80.6	40	2,0	8	8	5	L-9	L+16	8	4,5	70	1000	0,2241	0,0076	0,1162	0,0037				
553.0.100.6			10	10	6		L+20	10				0,2687	0,0098						
553.0.120.6			12	12	8		L+24	12				0,3218	0,0125						
553.0.80.8	50	2,8	8	8	5		L+16	8				0,3234	0,0102	0,1960	0,0063				
553.0.100.8			10	10	6		L+20	10				0,3664	0,0125						
553.0.110.8			ES11	ES11	6		L+22	11				0,4062	0,0145						
553.0.120.8			12	12	8		L+24	12				0,4188	0,0152						
553.0.140.8			14	14	8		L+28	14				0,4812	0,0184						
553.0.80.25			63	3,0	8		8	5				L+16	8			0,3886	0,0124	0,2672	0,0086
553.0.100.25					10		10	6				L+20	10			0,4315	0,0147		
553.0.110.25	ES11	ES11			6		L+22	11				0,4715	0,0167						
553.0.120.25	12	12			8		L+24	12				0,4841	0,0174						
553.0.140.25	14	14			8		L+28	14				0,5464	0,0206						
553.0.110.27	90	4,3	ES11	ES11	6		L+22	11				0,7228	0,0258	0,5163	0,0175				
553.0.120.27			12	12	8		L+24	12				0,7354	0,0265						
553.0.140.27			14	14	8	L+28	14	0,7978	0,0297										

Tabelle 8 **Cs Statische Rollenbelastbarkeit in Abhängigkeit von der Länge**
carga estática de los rodillos en función de su longitud Tabla 8

D	d = mm Achsendurchmesser diámetro del eje del rodillo					L = mm Rollenlänge longitud del rodillo									
	8	10	ES11	12	14	200	300	400	500	600	700	800	900	1000	
	Rollentyp tipo rodillo					Cs = daN ≈ kgf									
40	553.0.80.6	553.0.100.6		553.0.120.6		43	28	20	16	10	6				
50		553.0.100.8	553.0.110.8	553.0.120.8	553.0.140.8	54	35	25	20	13	8	6			
63			553.0.110.25	553.0.120.25	553.0.140.25	94	60	50	45	25	15	10	9	4	
90			553.0.110.27	553.0.120.27	553.0.140.27	110	69	58	52	29	17	12	10	5	

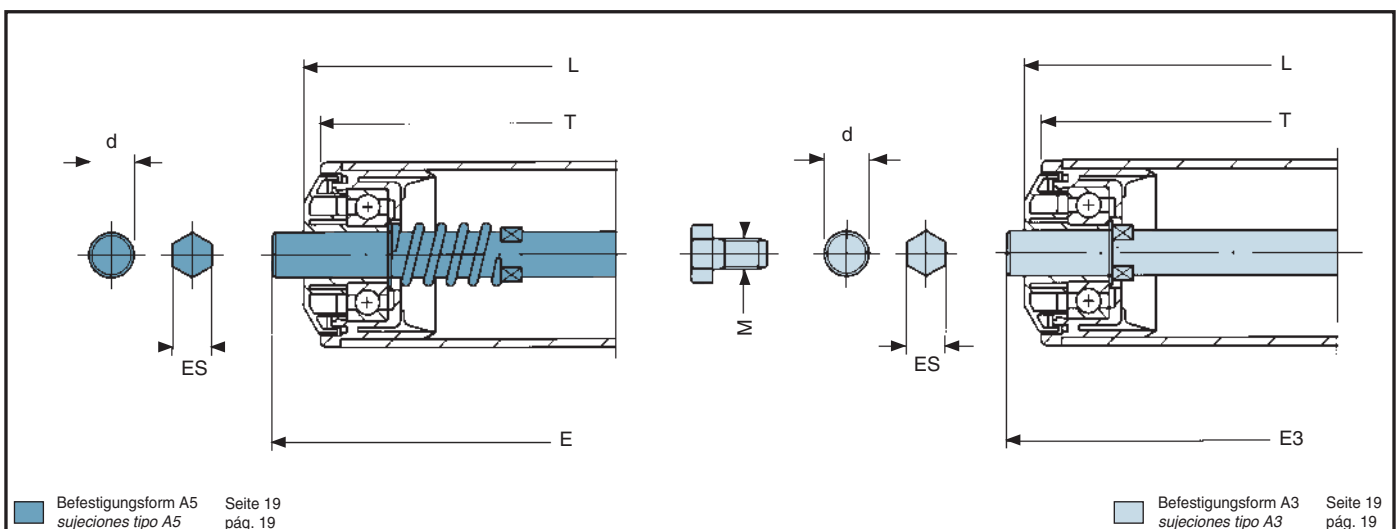
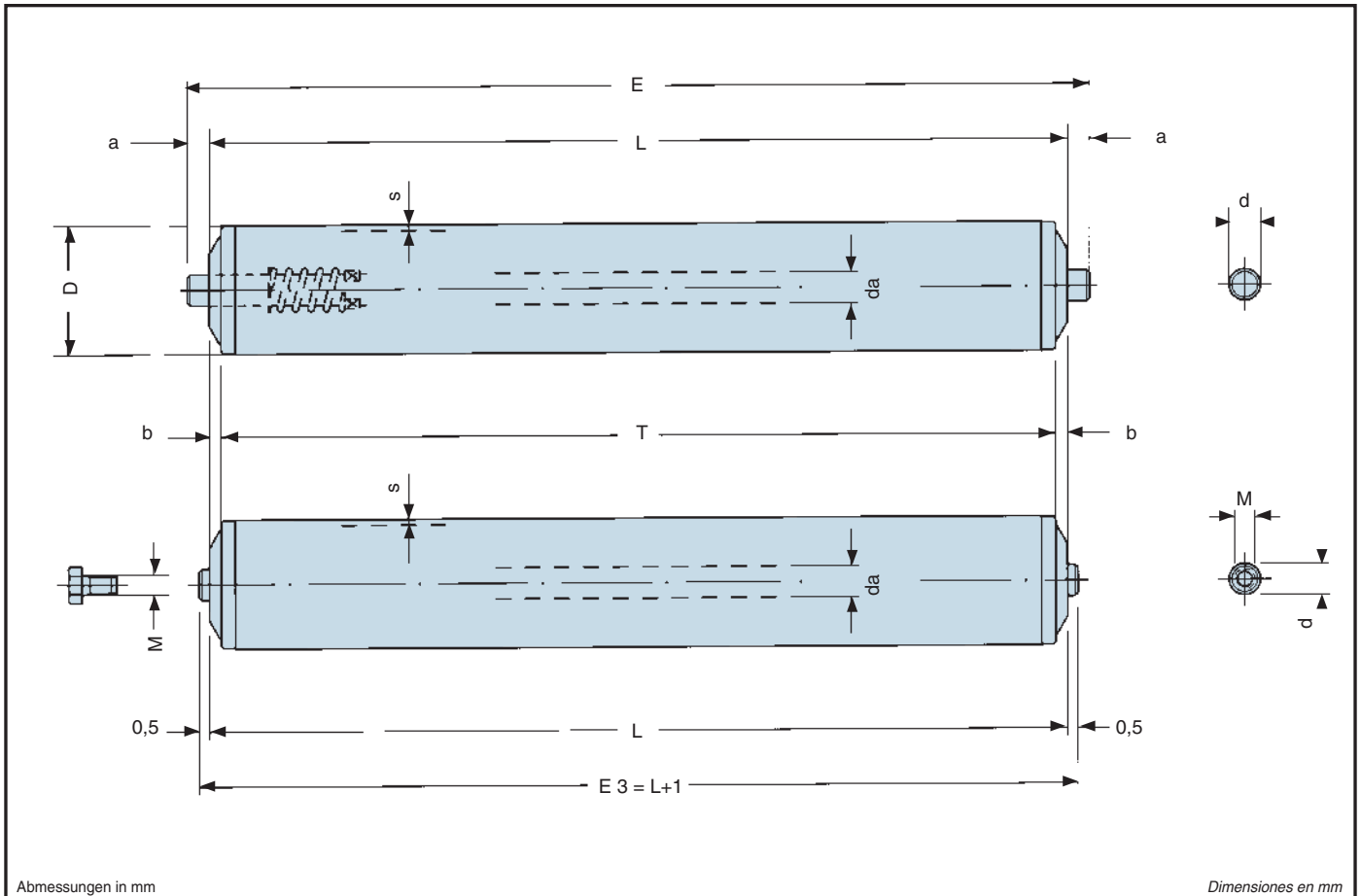
Tabelle 9 **Cd Dynamische Rollenbelastbarkeit in Abhängigkeit von der Anlagengeschwindigkeit**
carga dinámica de los rodillos en función de la velocidad del transportador Tabla 9

D	d = mm Achsendurchmesser diámetro del eje del rodillo					v = m/s Anlagengeschwindigkeit velocidad del transportador									
	8	10	ES11	12	14	0,05	0,10	0,20	0,30	0,40	0,50	0,60	0,70	0,75	
	Rollentyp tipo rodillo					Cd = daN ≈ kgf									
40	553.0.80.6	553.0.100.6		553.0.120.6		98	70	48	39	34					
50		553.0.100.8	553.0.110.8	553.0.120.8	553.0.140.8	132	81	55	45	40	34	6			
63			553.0.110.25	553.0.120.25	553.0.140.25	117	92	64	50	44	40	36	32	31	
90			553.0.110.27	553.0.120.27	553.0.140.27	154	132	81	61	51	46	43	40	38	

Tabelle 10 **Cd Dynamische Rollenbelastbarkeit in Abhängigkeit von der Drehzahl**
carga dinámica de los rodillos en función de su número de revoluciones Tabla 10

n = 1/min Rollendrehzahl número de revoluciones del rodillo									
n	10	25	50	75	100	150	200	250	300
Rolle Serie serie rodillo	Cd = daN ≈ kgf								
553.0	155	98	70	55	47	40	33	30	25